

no.
45

NAKAKITA SEISAKUSHO CO.,LTD.

NAKAKITA SEISAKUSHO CO., LTD.

<http://www.nakakita-s.co.jp/>

1-1 Fukano-Minami-Machi, Daito, Osaka, 574-8691, Japan

Tel : +81-72-871-1331 / Fax : +81-72-874-3185 / E-mail : bus@nakakita-s.co.jp

AHTS	PSV	FPSO	Drill Ship	Semi-sub

Product

AUTOMATIC CONTROL VALVE / CONTROLLER

PNEUMATIC TYPE, ELECTRIC MOTOR DRIVEN TYPE



VALVE REMOTE CONTROL SYSTEM AND VALVE

REMOTE OPERATED BY HYDRAULIC, PNEUMATIC, MOTOR DRIVEN AND MANUAL HANDLE TYPE

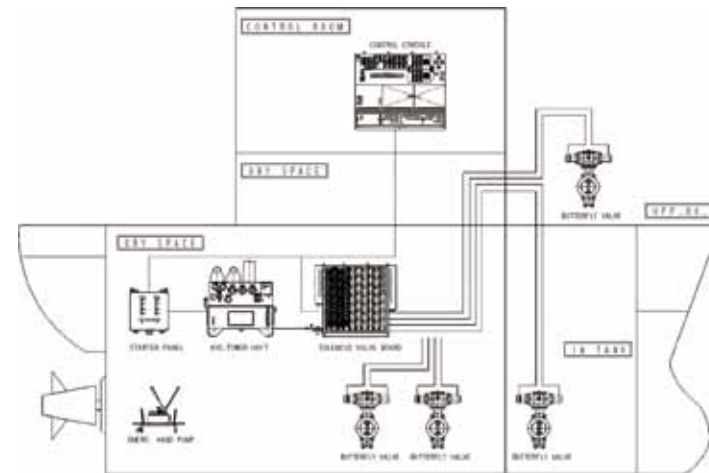

Hydraulic power unit



Solenoid valve board



Emergency hand pump



Butterfly valve

TANK LEVEL GAUGING SYSTEM

AIR PURGE TYPE, FLOAT TYPE, PRESSURE TYPE

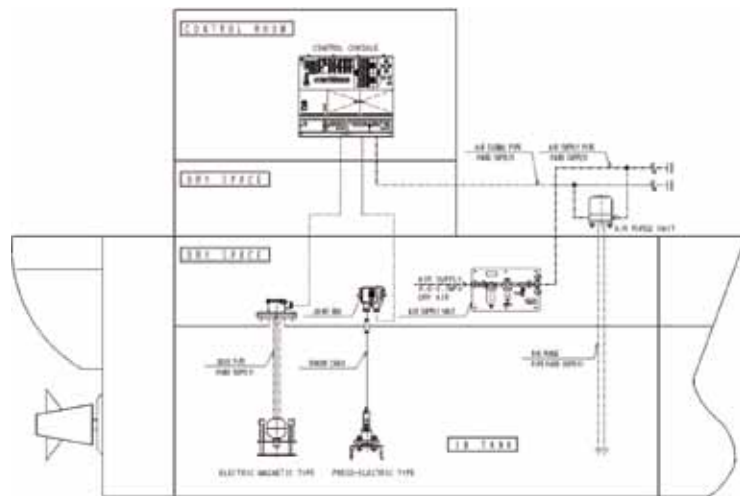

After-sales service

To ensure prolonged use of our products all over the world, we have expanded the after-sales service network. We have compiled the database of the records of delivery and established our system for ensuring longer and safer use of our products.

JAPAN : NAKAKITA
SINGAPORE & MALAYSIA : YOKOSIN MARINE
EUROPE : RAVEBO B.V.
OTHER : FUJI TRADING(Details <http://www.fujitrading.co.jp>)
 ISS MACHINERY(Details <http://www.issmachinery.com>)

Record

For Petrobras, For Modec and etc.
 FPSO, FSO, LPG FSO, RIG, AHTS
 TOTAL ABOUT 100 SHIPS

Package

We can supply the remote control butterfly valve for cargo & ballast line including the cargo control console and system devices of hydraulic system and etc. as a package.

Therefore, we can support for the trouble promptly.
 Moreover, we can supply the level gauging system for cargo, ballast & fuel oil tank.
 In addition, we have much supply records for the control valve & controller in engine room as a specialist of fluid control maker.

Please tell us an inquiry to the following.

Tel : +81-72-871-1331 E-mail : bus@nakakita-s.co.jp

Certifications/Applicable rules

ISO9001 (LRQA)

CE MARKING (LRQA)

ASME

TYPE APPROVAL : NK, LR, ABS, DNV · GL